

Working area · Machine dimensions

Working area

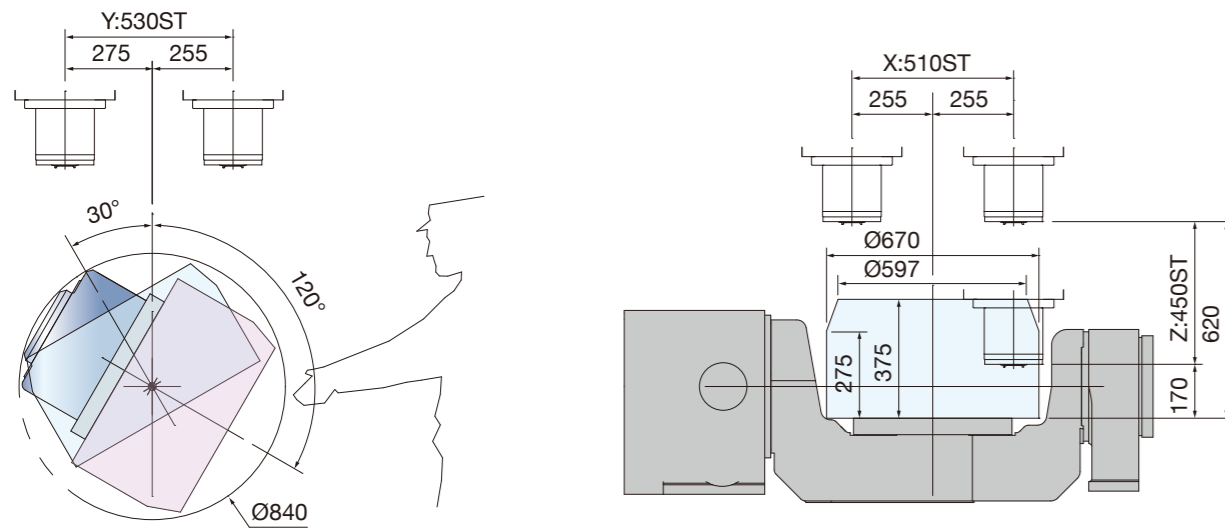

Machine dimensions

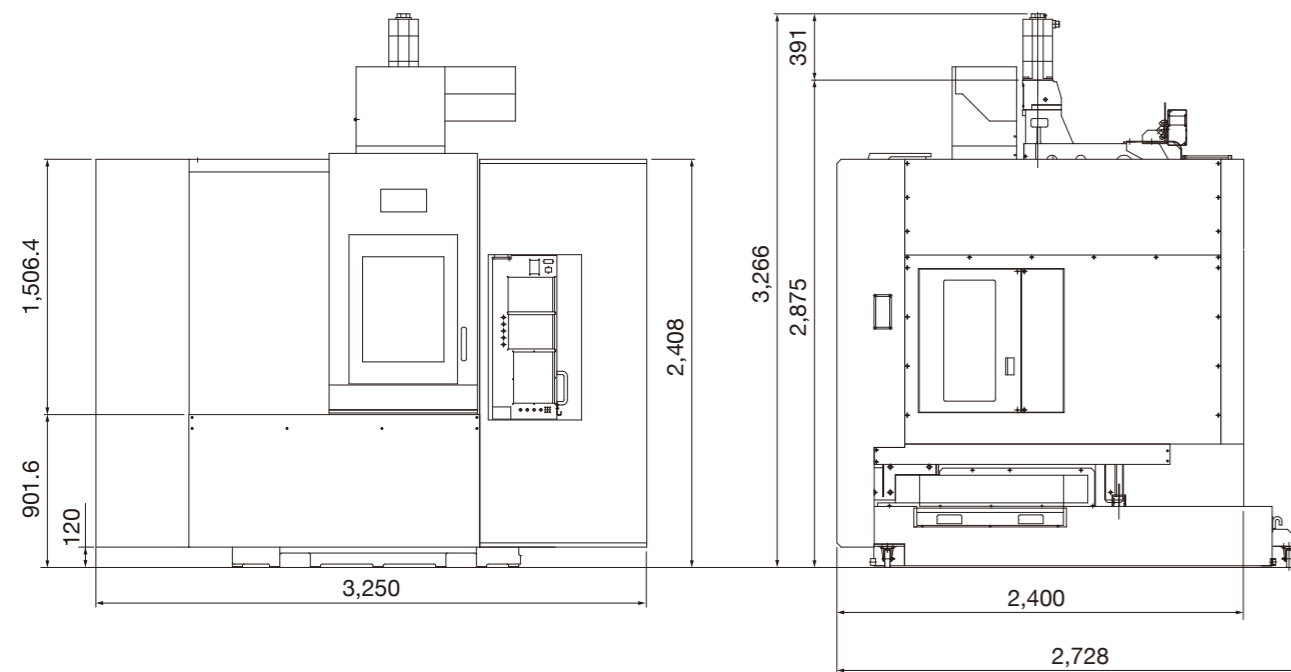

unit : mm

Specification

Item	Specification	Unit	MDV-551-5AXII
Table	Table size	mm	Ø500
	Max. table load	kg	400
	Table height from floor	mm	1,130
	Max. workpiece dimension (diameter×height)	mm	Ø670×375 (Shape limited)
	A/C axis min. indexing increment	deg	0.001°
Spindle	Spindle taper		7/24 Taper No. 40
	Spindle speed	rpm	Built-in type 15,000 (Opt. 20,000)
Stroke	X/Y/Z axis stroke	mm	510/530/450
	Spindle nose to table	mm	170-620
	A axis stroke	deg	+30° ~ -120°
	C axis stroke	deg	±360°
Feed	X/Y/Z axis rapid traverse	m/min	48/48/48
	A/C axis rapid traverse	rpm	30/50 (Roller gear)
	Cutting feedrate	mm/min	1-20,000
ATC	Tool shank		BBT-40 (Opt. HSK-A63)
	Tool capacity	pc	16 (Opt. 30/60)
	Max. tool diameter	mm	Ø110 (Opt. 60 tools : Ø95)
	Max. tool diameter (w/o adjacent tool)	mm	- (Opt. 60 tools : Ø125)
	Max. tool length	mm	300
Motor	Spindle motor	kW	40/40 (Opt. 40/30)
	X/Y/Z axis servo motor	kW	8.6/8.6/8.6
	Coolant motor	kW	0.37×2
Machine size	Wide x Depth x Height	mm	3,250×2,400×3,270
	Weight	kg	11,000
Controller			Heidenhain

©specifications may be changed without prior notice

www.tongtai.com.tw

Tongtai
Trust & Technology

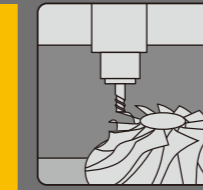

MDV-551-5AXII

Five-Axis Vertical Machining Center

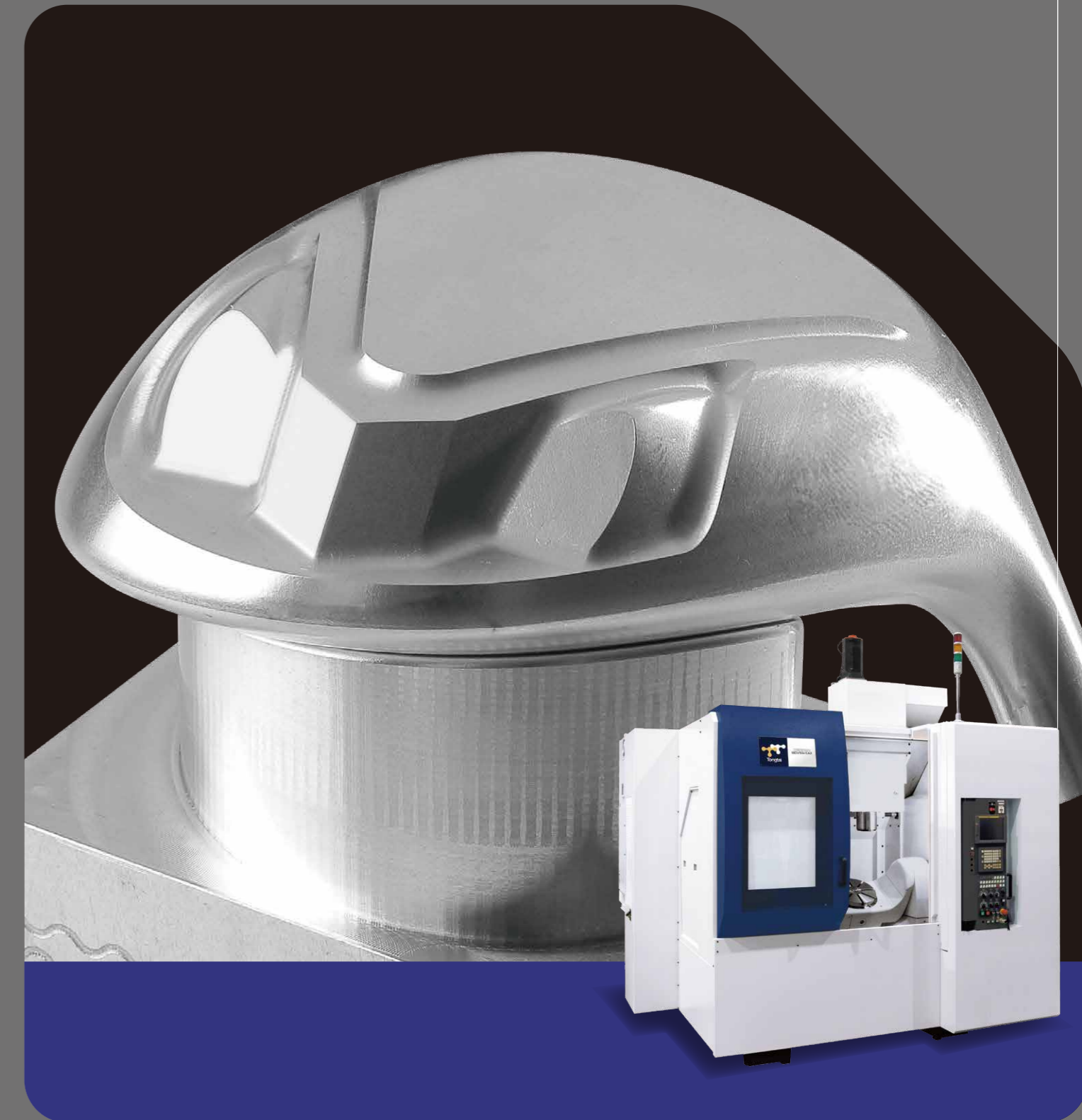

Tongtai Tongtai Machine & Tool Co., Ltd.

Headquarters

No.3, Luke 3rd Rd., Luzhu Dist., Kaohsiung City 82151, Taiwan

TEL : 886-7-9761588

FAX : 886-7-9761589, 886-7-9761590

Website : www.tongtai.com.tw

Taoyuan Office	TEL : 886-3-4551399	FAX : 886-3-4559730
Taichung Office	TEL : 886-4-23589600	FAX : 886-4-23589993
Japan Branch	TEL : 81-4-71438355	FAX : 81-4-71438360
Europe Branch	TEL : 31-161-454639	FAX : 31-161-454768
Malaysia Branch	TEL : 603-78597113	FAX : 603-78597115
Vietnam Office	TEL : 84-4-62766090	
Thailand Office	TEL : 66-2-7443440	FAX : 66-2-3986518
Indonesia Office	TEL : 62-21-45850875	FAX : 62-21-45850876

Affiliates

Honor Seiki Co., Ltd.

TEL: 886-7-9759888

FAX: 886-7-9759999

Website : www.honorseiki.com.tw

Asia Pacific Elite Corp.

TEL: 886-4-23589313

FAX: 886-4-23588913

Website : www.apecnc.com

China Operation Center

Shuzhou Tong-yu Machine & Tool Co., Ltd.

No.555 Huahong Road, Economic Development Zone,

Songling Town, Wujiang City, Jiangsu Province, China

TEL : 86-512-63430168

FAX : 86-512-63431622

E-mail : sales@tong-yu.com.cn

Wuhan Branch	TEL : 86-27-59409109	FAX : 86-27-59409110
Chongqing Branch	TEL : 86-23-67865925	FAX : 86-23-67867717
Guandong Branch	TEL : 86-755-27222119	FAX : 86-755-27222115
Tianjin Branch	TEL : 86-22-24417640	FAX : 86-22-24416738
Shanghai Office	TEL : 86-21-24208138	FAX : 86-21-34073262
Shenyang Office	TEL : 86-24-24142968	FAX : 86-24-24115782

Quick-Tech Machinery Co., Ltd

TEL: 886-6-3841155

FAX: 886-6-3841177

Website : www.quicktech.com.tw



MDV-551-5AXII_2016.10.13

Spindle

15,000 rpm Built-in spindle

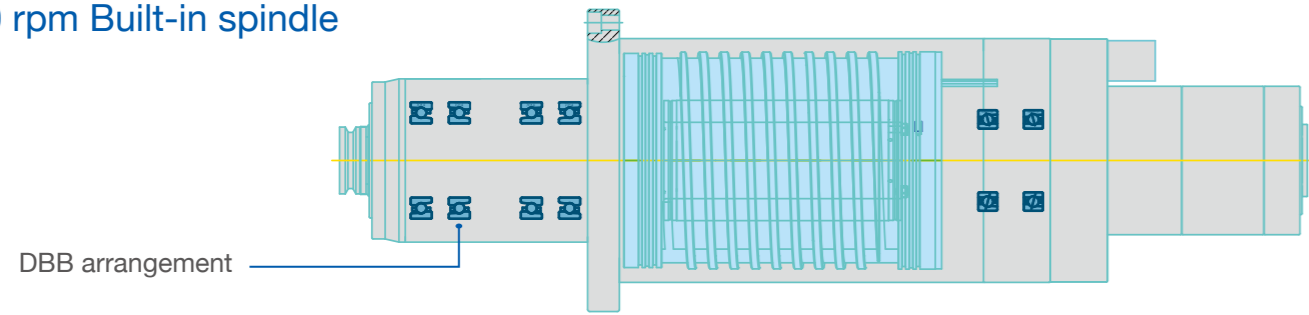

- The spindle is equipped with oil-air lubricated bearings and oil-cooling cartridge, it constrains the thermal generation and reduces the thermal expansion in spindle.
- Temperature control system will alarm and stop manufacturing while the spindle is overheated in order to prevent bearings from damage.
- 4 bearings are arranged in DBB type on front side to provide high rigidity while heavy duty cutting.
- BBT dual-contact tool holder is equipped to enhance the stability and machining quality.

20,000 rpm Built-in spindle

- The spindle is equipped with oil-air lubricated bearings and oil-cooling cartridge, it constrains the thermal generation and reduces the thermal expansion in spindle.
- Temperature control system will alarm and stop manufacturing while the spindle temperature is too high, in order to prevent thermal damage of bearing.
- Floating sleeve on rear-end bearing is used to avoid the preload variation of bearing induced by thermal expansion and ensure bearing's lifetime.
- BBT dual-contact tool holder is equipped to enhance the stability and machining quality.

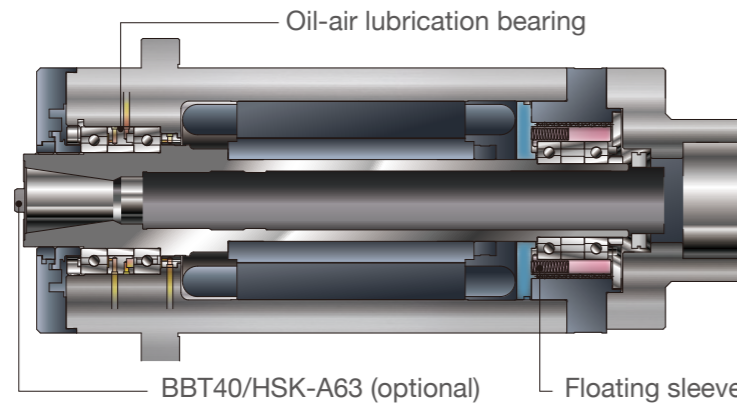

15,000 rpm Built-in spindle (std.)

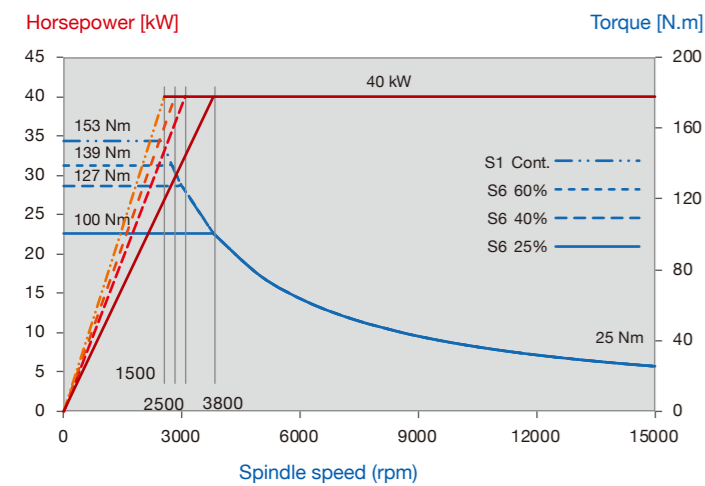

20,000 rpm Built-in spindle (opt.)

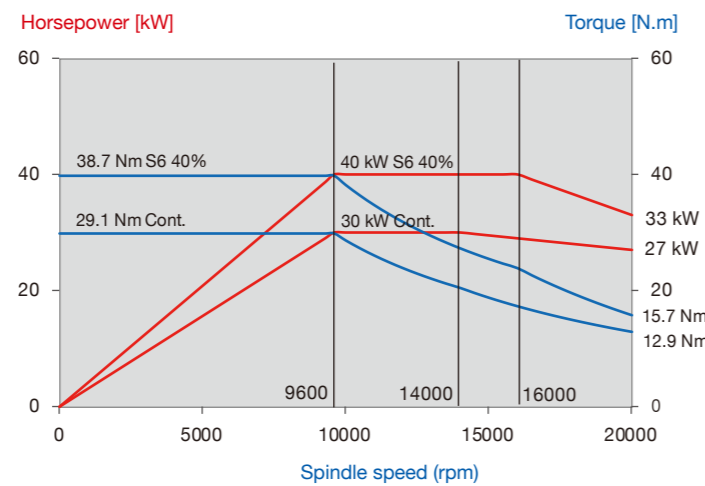

Structure

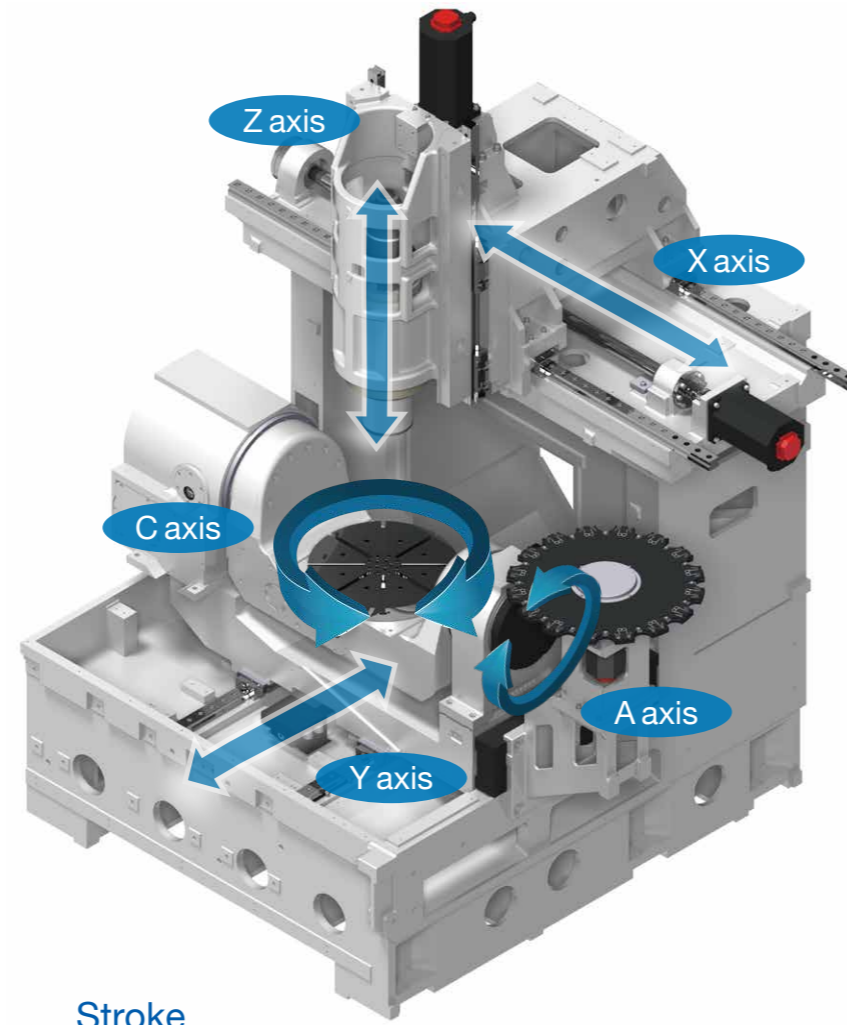

Stroke

X/Y/Z axis 510/530/450 mm
A/C axis 150(+30°~-120°)/360° mm

Rapid traverse

X/Y/Z axis 48/48/48 m/min
A/C axis 30/50 rpm

Zero backlash	A/C axis positioning accuracy	5.6"
High positioning accuracy	A/C axis repeatability accuracy	±3.0"
Low abrasion	A axis torque	1,900/6,566 Nm
Higher durability	C axis torque	778/2,981 Nm

Vibration comparison between roller gear cam and worm gear

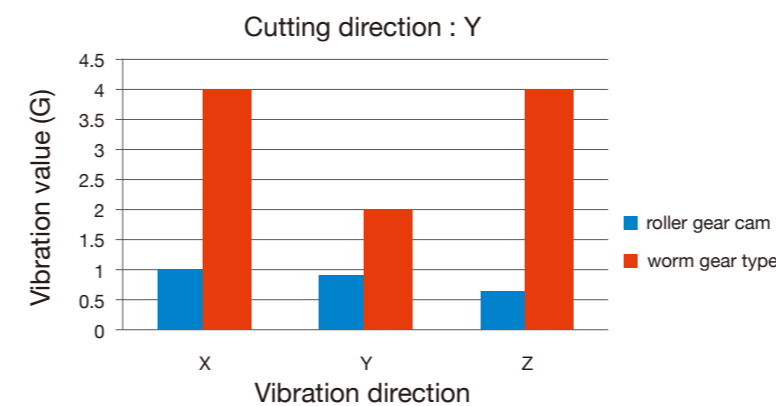
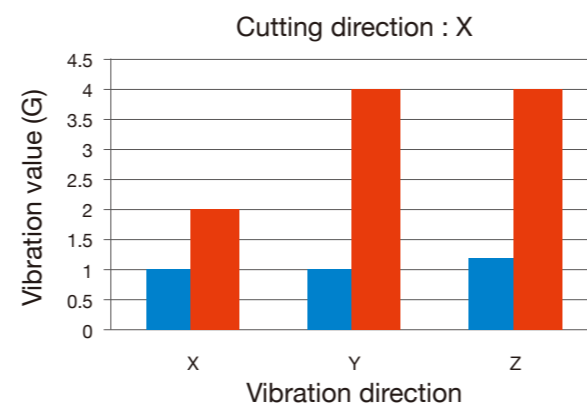

High rigidity roller gear cam mechanism rotary table

The positioning accuracy, repeatability accuracy, backlash and durability performances of roller gear cam mechanism are all better than worm-gear mechanism.



Because A/C axis rotary table is driven by roller gear cam with rolling contact between roller and cam, it can start at a lower torque. It is suitable for high speed rotation and high accuracy is guaranteed under long-term heavy duty cutting.

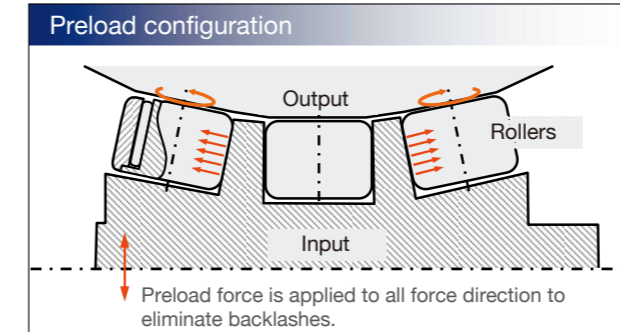

Rotating center is higher than table surface

Rotating center of A axis is 100 mm higher than table surface, it can reduce the distance of tool moving with table rotation simultaneously, decrease cycle time and improve surface accuracy of contouring.

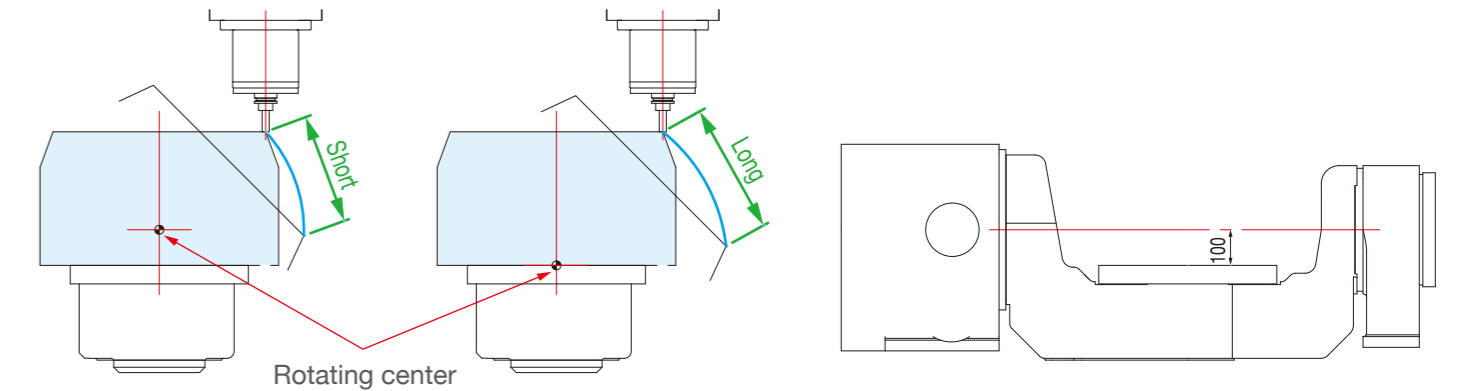

Spindle thermal deformation compensation (opt.)

- Built-in type temperature sensor detects the temperature of spindle bearing for protecting the bearing from overheating.
- According to the closest temperature of bearings, the thermal deformation compensation can be achieved correctly.
- Through thermal compensation, precision of each axis can be maintained below 20 μm.

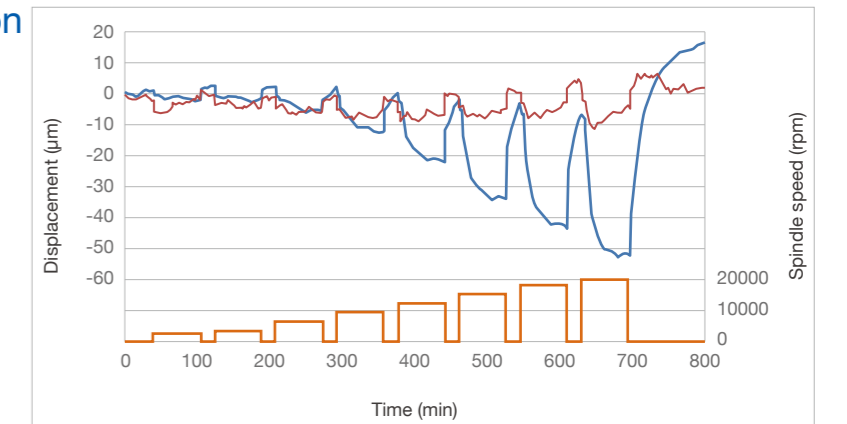

Diagram of thermal displacement on Z-axis

Rotating center detection for five-axis machining center (opt.)

1. Calibration of rotating centers
2. Tool length measurement
3. Tool breakage detection
4. Manual workpiece position measurement
5. Automatic workpiece position measurement

